

Kawasaki

— ENGINES —

PARTS CATALOG

4-STROKE AIR-COOLED GASOLINE ENGINE

PRODUCT CODE
FS541V-AG82
FS541V-BG82
FS541V-CG82

PARTS CATALOG INTRODUCTION

This parts catalog lists parts and sub-assemblies provided as service parts. When it becomes necessary to replace parts, always use KAWASAKI GENUINE PARTS which have passed strict inspection which guarantees quality and performance.

1. HOW TO ORDER PARTS

- 1) When ordering the parts, be sure to use the parts catalog corresponding to the product code. Check the product revision codes on the product and the catalog.

Product Code (example) : FA130D-AA00
 Product Revision Code

- 2) Specify the part code (all digits) exactly as listed in this catalog on your parts order.
- 3) The parts not shown in the illustrations of this catalog are not sold separately; only the complete units or next higher assemblies illustrated are supplied as the service parts.

2. EXPLANATION OF PARTS CATALOG FORMAT

Ref. No.	Part No.	Description	Quantity
			c
			6
14091	14091-2141	COVER	1
19073	19073-2241	INSULATOR	1
21169	21169-2077	TERMINAL	1
21171	21171-2267	COIL-ASSY-IGNITION	1
21194	21194-2355	FLYWHEEL-COMP	1
29011	29011-2390	WIRE-LEAD	1
92038	92038-2107	KEY	1
92070	92070-2119	PLUG-SPARK(BPRSES(NGK)	1
92154	92154-2014	BOLT,4X18	1
92154A	92154-2018	BOLT,6X20	2
92154B	92154-2017	BOLT,12X30	1
92200	92200-2183	WASHER,4.5X8X0.5	1
92210	92210-2126	NUT,M4	1

1) Product Code

This code describes the product code covered by this catalog. The product revision code, which is a part of the product code, is omitted.

2) Part Group Title

This title is the representative name for the group of parts illustrated on the page.

3) Reference Number

The reference numbers are shown on the illustration and the list as the link between them.

4) Part Number

This is the key of your parts ordering. Three kinds of part number are used in this catalog.

a. Structure 1

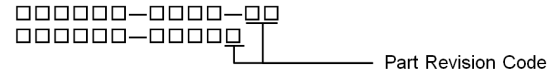

b. Structure 2

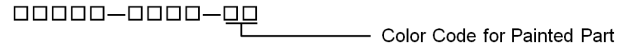

c. Standard Hardware Number

(for bolts, nuts, washer, or the like)



5) Description and Additional Information

The part name, the location, the size, and the serial number as additional information, etc. are described here. Use them to find out and check the part required.

When a part number is changed without change of the product revision code and the changed parts are not interchangeable, the serial number of the product is noted as follows;

- (- FA130 - 100001) Affected units are from beginning of the product of the product code up to and including this serial number.
- (FA130 - 100002 -) Affected units are from this serial number and above.
- (FA130 - 100002 - FA130 - 110001) Affected units are in this serial number range.

6) Quantity

The figure shows quantity of the part required at the indicated position on the illustration and for the specified product revision code.

The asterisk (*) on this column means the part can be used as the substitute on the product and is supplied until the stock is exhausted.

Note: Some small parts will be supplied by units.

Example: If six (6) bolts are ordered and the minimum quantity per unit is five (5), two (2), units of the bolt will be delivered.

7) Product Revision Code

This Code indicates an important change which affects the service parts interchangeability.

3. ABBREVIATIONS

#	Number	FR	Front	RH	Right Hand
&	And	G	Gram	RPM	Revolutions Per Minute
(+)	Plus	HEX	Hexagonal	RR	Rear
(-)	Minus	ID =	Inside Diameter	STD	Standard
2ND	Second	IN	Inch	T	Teeth
3RD	Third	L =	Length	T =	Thickness
4TH	Fourth	LH	Left Hand	U/S	Under Size
A	Ampere	LWR	Lower	UPP	Upper
AR	As Required	MM	Millimeter	V	Volt
ASSY	Assembly	O/S	Over Size	W	Watt
CNT	Center	OD =	Outside Diameter		
COMP	Complete	REF	Reference		

E0110-A931E

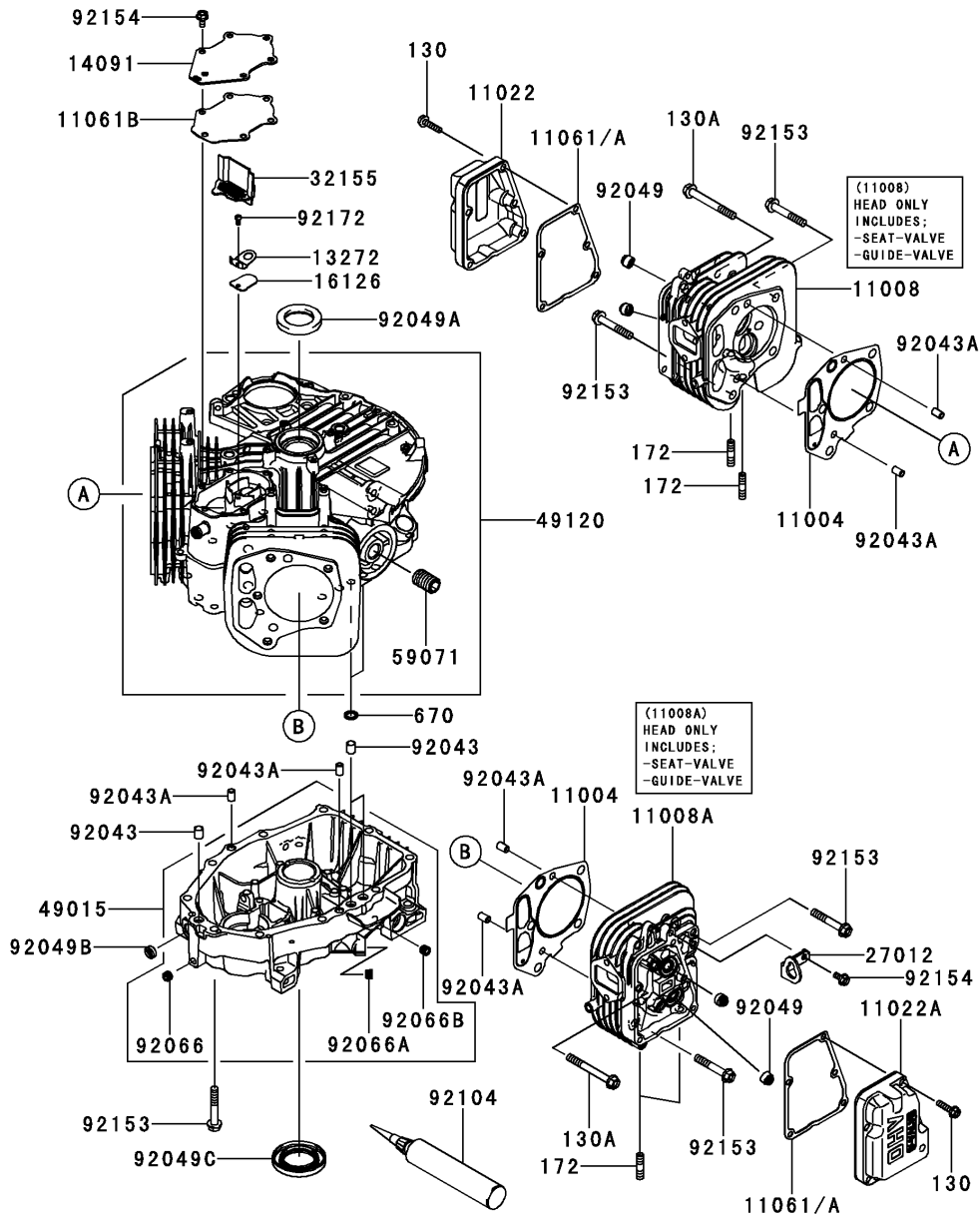

01. CYLINDER/CRANKCASE

Ref. No.	Part No.	Description	Quantity		
			AG82	BG82	CG82
11004	11004-7027	GASKET-HEAD	2	2	2
11008	11008-7050	HEAD-COMP-CYLINDER,#1	1	1	1
11008A	11008-7051	HEAD-COMP-CYLINDER,#2	1	1	1
11022	11022-0046	CASE-ROCKER,#1CYL	1	1	1
11022A	11022-0047	CASE-ROCKER,#2CYL	1	1	1
11061	11061-1285	GASKET,CASE-ROCKER		2	2
11061A	11061-7083	GASKET,CASE-ROCKER	2		
11061B	11061-7094	GASKET,BREATHER	1	1	1
13272	13272-1374	PLATE	1	1	1
14091	14091-7064	COVER,BREATHER	1	1	1
16126	16126-7020	VALVE,BREATHER	1	1	1
27012	27012-0721	HOOK,LIFT	1	1	1
32155	32155-2214	PIPE,BREATHER	1	1	1
49015	49015-0019	COVER-CRANKCASE	1	1	1
49120	49120-0883	CRANKCASE-COMP	1	1	1
59071	59071-0743	JOINT,OIL FILTER	1	1	1
92043	92043-0858	PIN	3	3	3
92043A	92043-1263	PIN,6.2X8X14	6	6	6
92049	92049-7001	SEAL-OIL,RVC2 6X11X10.2	4	4	4
92049A	92049-7010	SEAL-OIL,SD 35X48X8 R HS	1	1	1
92049B	92049-7019	SEAL-OIL,SO 8X14X5 HS	1	1	1
92049C	92049-7028	SEAL-OIL,38X62X8MTCLV	1	1	1
92066	92066-0880	PLUG,OIL	1	1	1
92066A	92066-0881	PLUG	1	1	1
92066B	92066-2223	PLUG	1	1	1
92104	92104-0007	GASKET-LIQUID,TB1217H	AR	AR	AR
92153	92153-7054	BOLT,8X50	14	14	14
92154	92154-2938	BOLT,6X12	7	7	7
92172	92172-0870	SCREW,4X8	1	1	1
130	130BA0625	BOLT-FLANGED,6X25	10	10	10
130A	130CA0870	BOLT-FLANGED,8X70	6	6	6
172	172BA0822	BOLT-STUD,8X22	4	4	4
670	670B2011	O RING,11MM	2	2	2

E0120-A527C

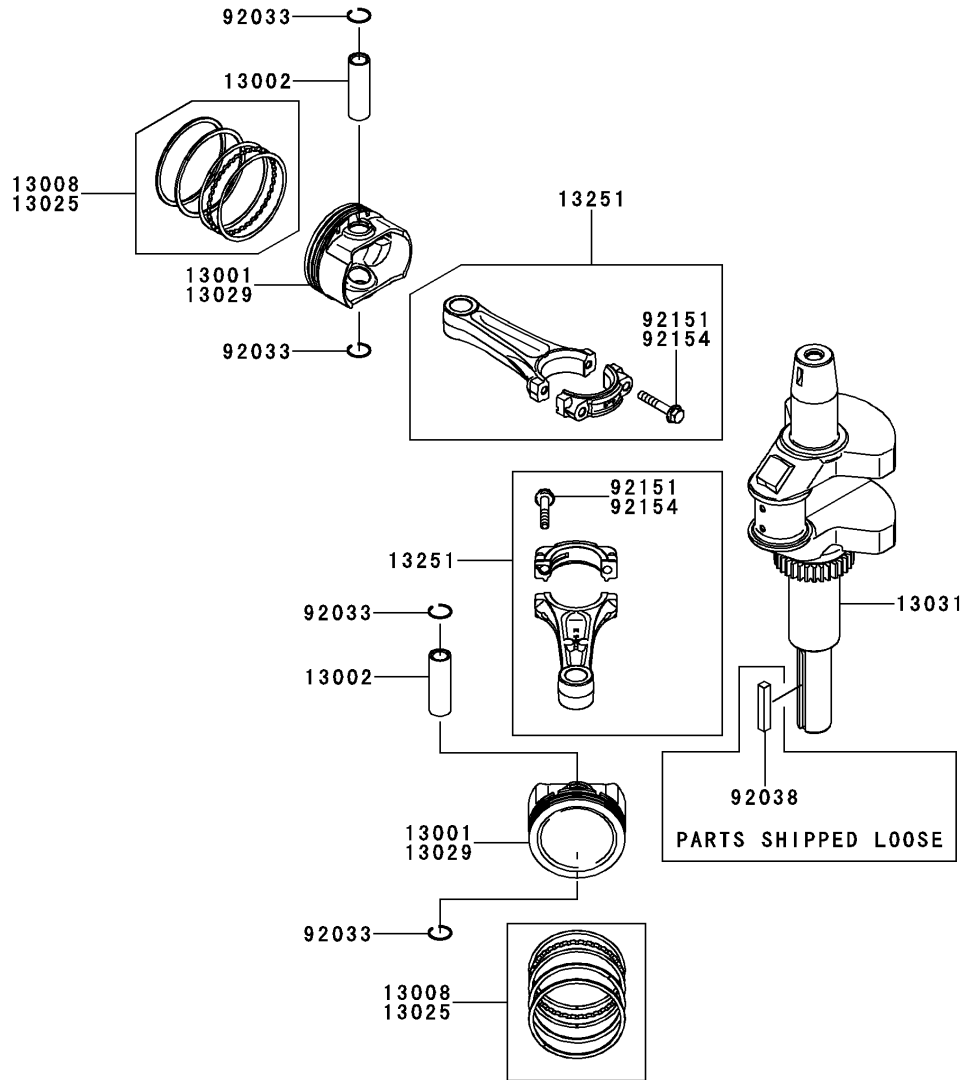

02. PISTON/CRANKSHAFT

Ref. No.	Part No.	Description	Quantity		
			AG82	BG82	CG82
13001	13001-7031	PISTON-ENGINE	2	2	2
13002	13002-7001	PIN-PISTON	2	2	2
13008	13008-7006	RING-SET-PISTON	2	2	2
13025	13025-7010	RING-SET-PISTON L,0.50	AR	AR	AR
13029	13029-7011	PISTON-ENGINE L,0.50	AR	AR	AR
13031	13031-0814	CRANKSHAFT-COMP	1	1	1
13251	13251-0718	ROD-ASSY-CONNECTING	2	2	2
92033	92033-0780	RING-SNAP	4	4	4
92038	92038-2101	KEY	1	1	1
92151	92151-7017	BOLT,6X35	4		
92154	92154-2842	BOLT,6X35		4	4

E0130-A216W

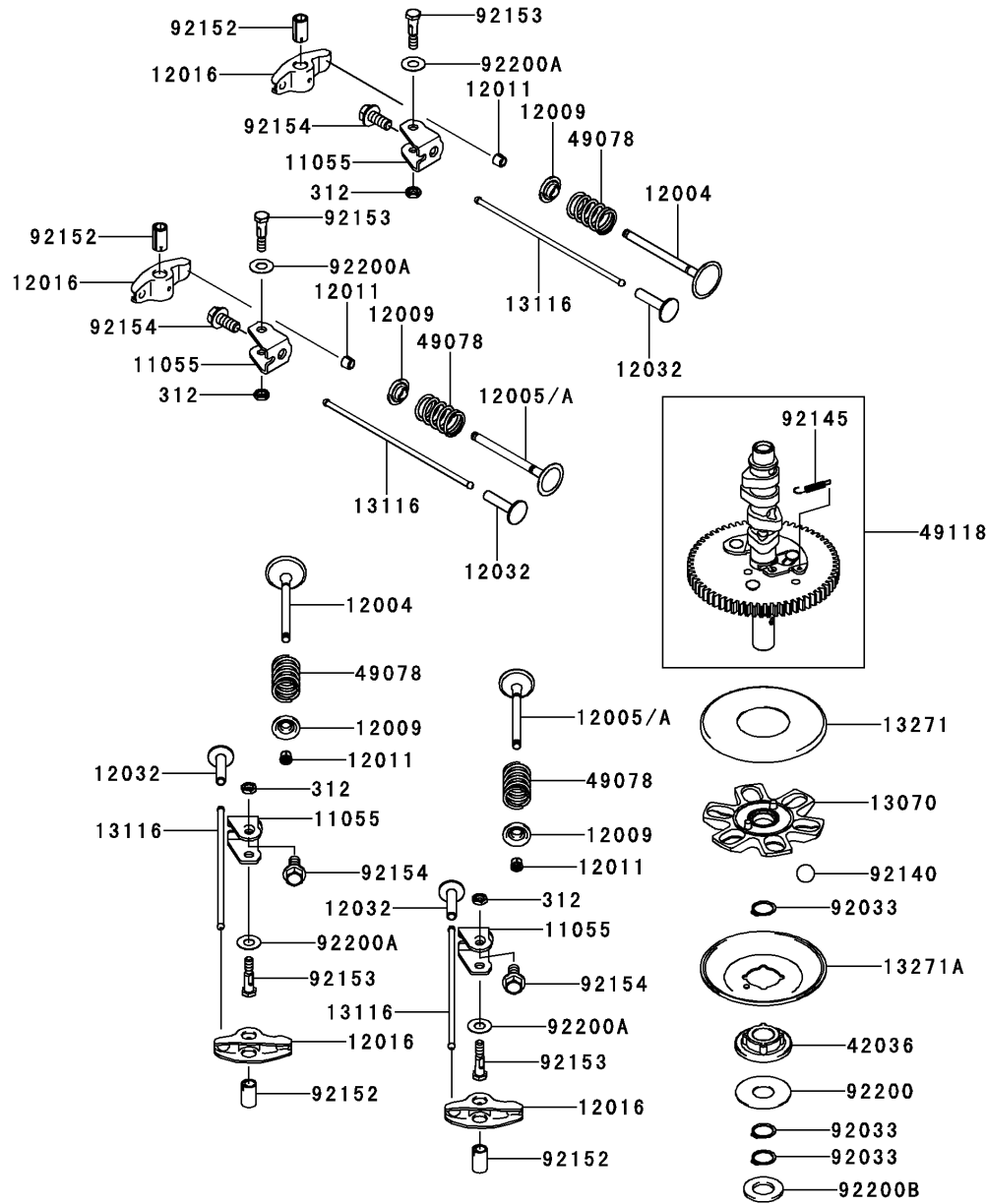

03. VALVE/CAMSHAFT

Ref. No.	Part No.	Description	Quantity		
			AG82	BG82	CG82
11055	11055-7009	BRACKET	4	4	4
12004	12004-0740	VALVE-INTAKE	2	2	2
12005	12005-0760	VALVE-EXHAUST	2		
12005A	12005-0793	VALVE-EXHAUST		2	2
12009	12009-7001	RETAINER-VALVE SPRING	4	4	4
12011	12011-2056	COLLET	8	8	8
12016	12016-0040	ARM-ROCKER	4	4	4
12032	12032-7001	TAPPET	4	4	4
13070	13070-7017	GUIDE,GOVERNOR	1	1	1
13116	13116-7008	ROD-PUSH	4	4	4
13271	13271-7007	PLATE	1	1	1
13271A	13271-7021	PLATE,GOVERNOR	1	1	1
42036	42036-7021	SLEEVE	1	1	1
49078	49078-7002	SPRING-ENGINE VALVE,IN	4	4	4
49118	49118-0809	CAMSHAFT-COMP	1	1	1
92033	92033-0778	RING-SNAP	3	3	3
92140	92140-7005	BALL	6	6	6
92145	92145-1653	SPRING	1	1	1
92152	92152-1689	COLLAR	4	4	4
92153	92153-7100	BOLT,6X29.5	4	4	4
92154	92154-1267	BOLT,8X18.2	4	4	4
92200	92200-0945	WASHER,16X42X0.91	1	1	1
92200A	92200-2151	WASHER,8.1X18X0.5	4	4	4
92200B	92200-7048	WASHER,16.3X30X2.28	1	1	1
312	312AA0600	NUT-HEX,6MM	4	4	4

E0140-A506S

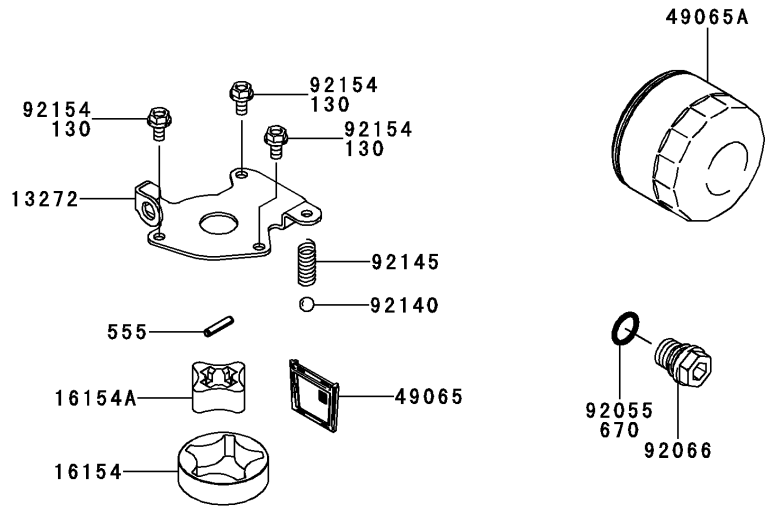
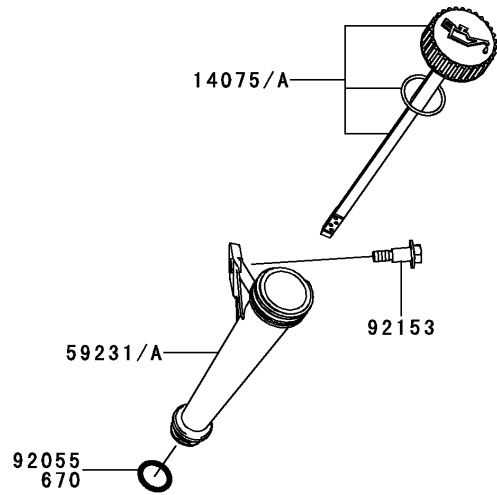

04. LUBRICATION-EQUIPMENT

Ref. No.	Part No.	Description	Quantity		
			AG82	BG82	CG82
13272	13272-7011	PLATE,ROTOR	1	1	1
14075	14075-0037	CAP-ASSY	1		
14075A	14075-0707	CAP-ASSY		1	1
16154	16154-7010	ROTOR-PUMP,OUTER	1	1	1
16154A	16154-7011	ROTOR-PUMP,INNER	1	1	1
49065	49065-7006	FILTER-OIL	1	1	1
49065A	49065-7007	FILTER-OIL	1	1	1
59231	59231-0712	FILLER	1		
59231A	59231-0746	FILLER		1	1
92055	92055-0892	RING-O,15.8X2.4		2	2
92066	92066-0774	PLUG	1	1	1
92140	92140-7003	BALL,STEEL,13/32	1	1	1
92145	92145-1809	SPRING,OIL RELIEF	1	1	1
92153	92153-7008	BOLT	1	1	1
92154	92154-2938	BOLT,6X12		3	3
130	130BA0612	BOLT-FLANGED,6X12	3		
555	555A0420	PIN-SPRING,4X20	1	1	1
670	670D2016	O RING,16MM	2		

E0150-B313E

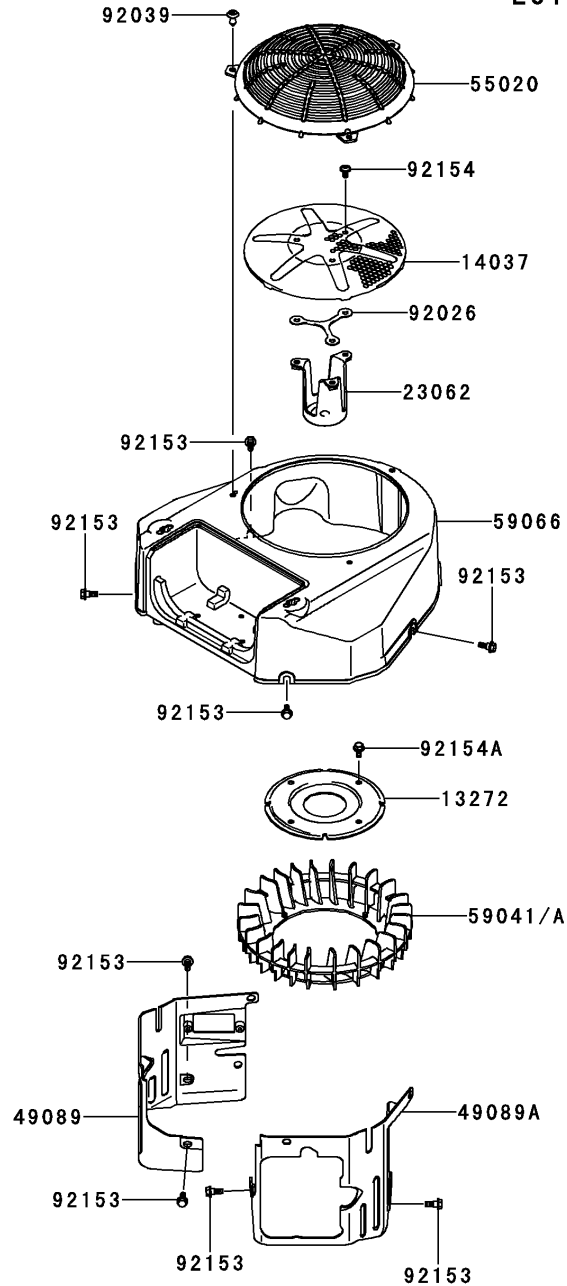

05. COOLING-EQUIPMENT

Ref. No.	Part No.	Description	Quantity		
			AG82	BG82	CG82
13272	13272-1487	PLATE,FAN	1	1	1
14037	14037-7008-9H	SCREEN	1	1	1
23062	23062-7022	BRACKET-COMP	1	1	1
49089	49089-0987	SHROUD-ENGINE	1	1	1
49089A	49089-0988	SHROUD-ENGINE	1	1	1
55020	55020-0900	GUARD	1	1	1
59041	59041-0008	FAN	1		
59041A	59041-0024	FAN		1	1
59066	59066-0044	HOUSING-FAN	1	1	1
92026	92026-7007	SPACER	1	1	1
92039	92039-0751	RIVET,GUARD	3	3	3
92153	92153-7007	BOLT,FLANGED,6X16	8	8	8
92154	92154-2687	BOLT,6X12	3	3	3
92154A	92154-2938	BOLT,6X12	4	4	4

E0160-B531N

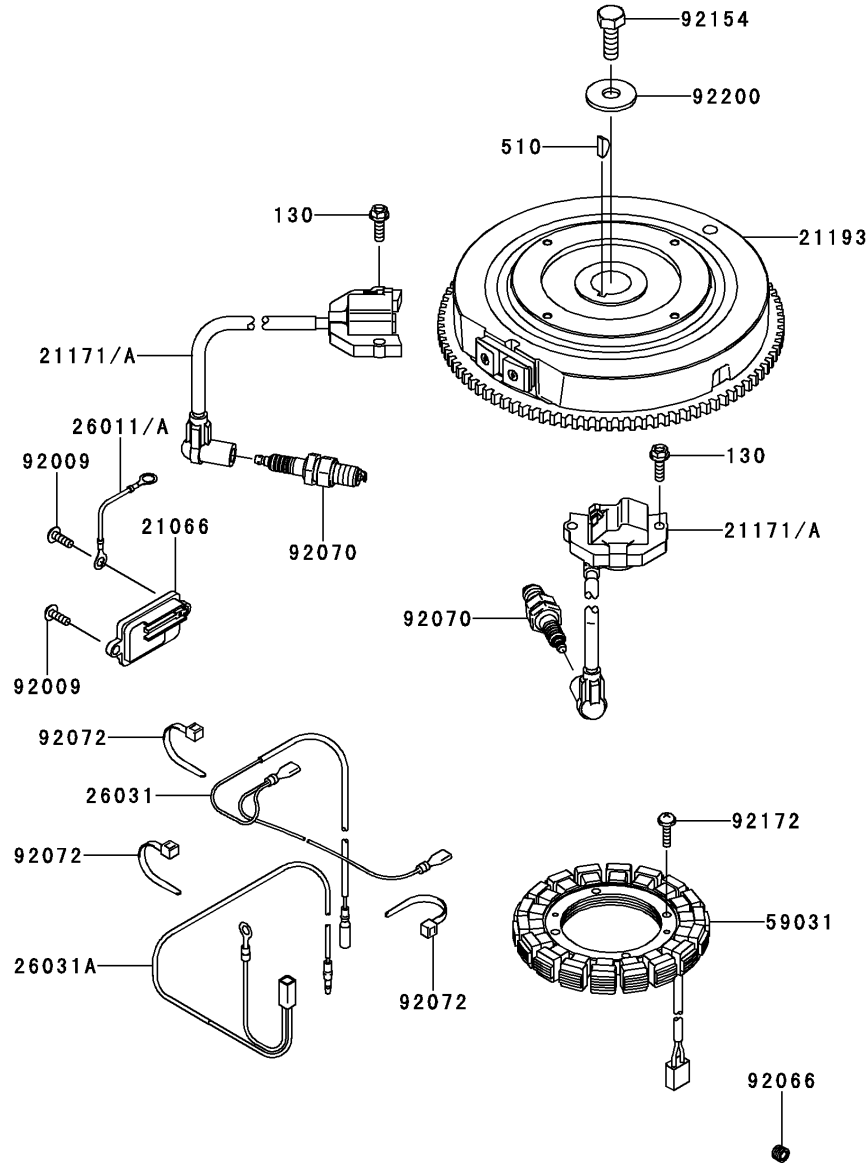

06. ELECTRIC-EQUIPMENT

Ref. No.	Part No.	Description	Quantity		
			AG82	BG82	CG82
21066	21066-7017	REGULATOR-VOLTAGE	1	1	1
21171	21171-0738	COIL-ASSY-IGNITION,#1 CYL	2		
21171A	21171-0740	COIL-ASSY-IGNITION	2	2	2
21193	21193-0035	FLYWHEEL-ASSY	1	1	1
26011	26011-2234	WIRE-LEAD		1	1
26011A	26011-7025	WIRE-LEAD,L=95	1		
26031	26031-7040	HARNESS	1	1	1
26031A	26031-7047	HARNESS	1	1	1
59031	59031-7017	COIL-CHARGING	1	1	1
92009	92009-2303	SCREW	2	2	2
92066	92066-0881	PLUG	1	1	1
92070	92070-7004	PLUG-SPARK,BPR4ES(NGK),SOLID	2	2	2
92072	92072-7003	BAND	3	3	3
92154	92154-7003	BOLT,12X30	1	1	1
92172	92172-7018	SCREW,5X20	4	4	4
92200	92200-7002	WASHER	1	1	1
130	130BA0620	BOLT-FLANGED,6X20	4	4	4
510	510A5100	KEY-WOODRUFF	1	1	1

E0170-A759Q

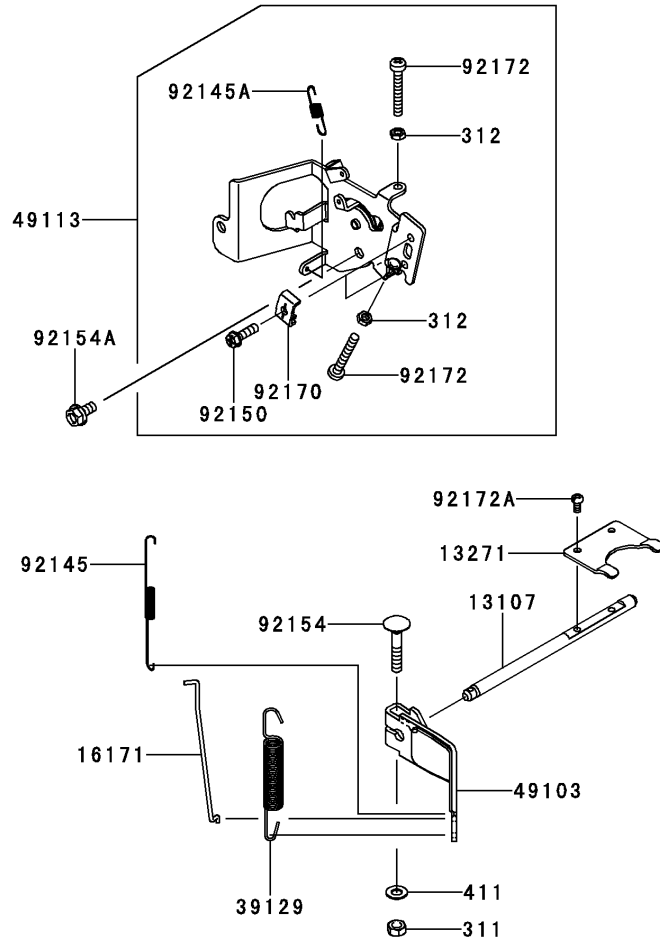

07. CONTROL-EQUIPMENT

Ref. No.	Part No.	Description	Quantity		
			AG82	BG82	CG82
13107	13107-7049	SHAFT	1	1	1
13271	13271-7038	PLATE	1	1	1
16171	16171-0035	LINK	1	1	1
39129	39129-0725	SPRING-GOVERNOR	1	1	1
49103	49103-7017	ARM-GOVERNOR	1	1	1
49113	49113-0047	PANEL-COMP-CONTROL	1	1	1
92145	92145-1811	SPRING, LINK	1	1	1
92145A	92145-7004	SPRING	1	1	1
92150	92150-2182	BOLT, 5X18	2	2	2
92154	92154-2697	BOLT, 6X35	1	1	1
92154A	92154-2938	BOLT, 6X12	1	1	1
92170	92170-7001	CLAMP	2	2	2
92172	92172-0792	SCREW, 5X35	2	2	2
92172A	92172-0870	SCREW, 4X8	2	2	2
311	311BA0600	NUT-HEX, 6MM	1	1	1
312	312AA0500	NUT-HEX, 5MM	2	2	2
411	411AA0600	WASHER-PLAIN, 6MM	1	1	1

E0180-B049B

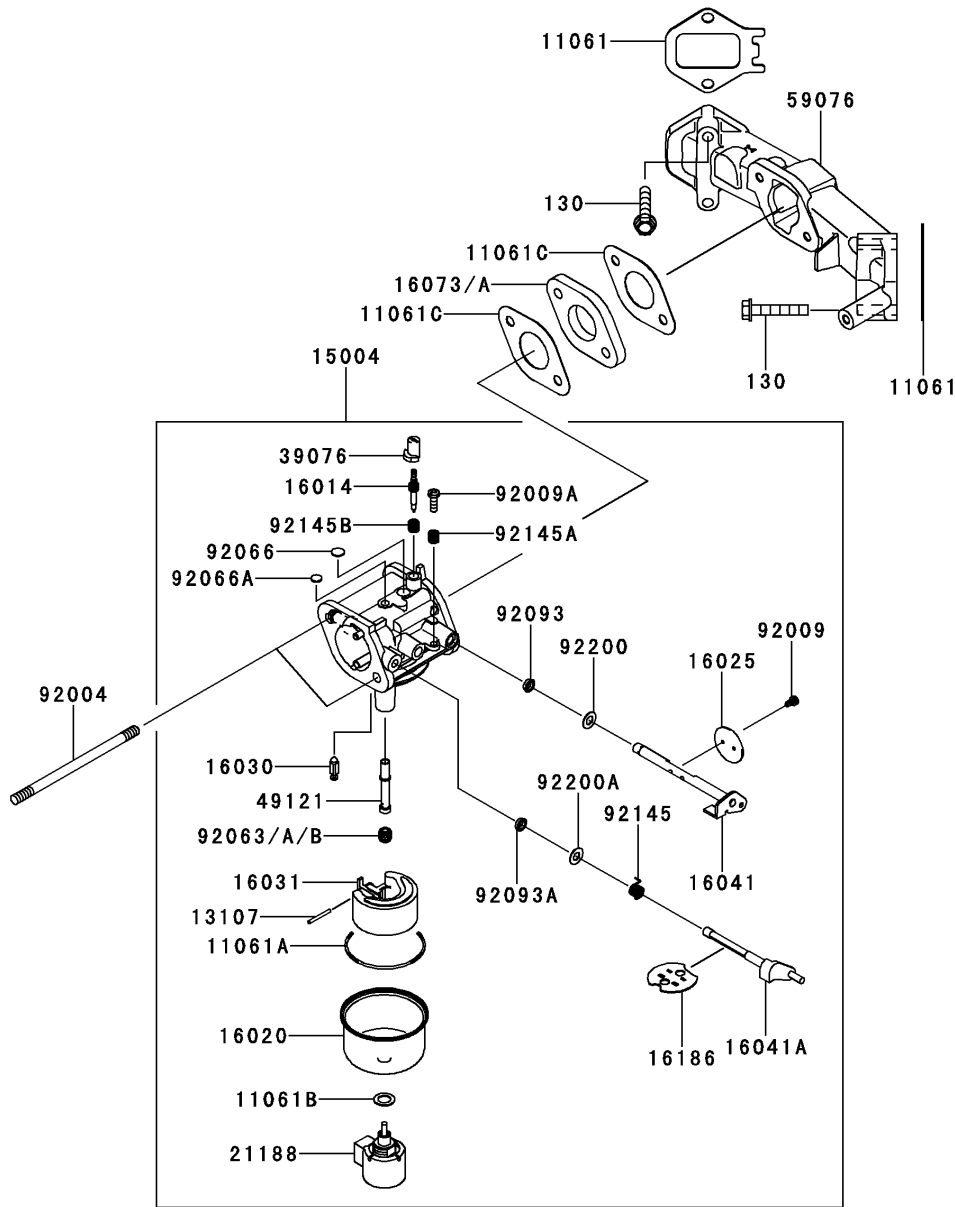

08. CARBURETOR

Ref. No.	Part No.	Description	Quantity		
			AG82	BG82	CG82
11061	11061-0877	GASKET,MANIFOLD	2	2	2
11061A	11061-7009	GASKET,CHAMBER	1	1	1
11061B	11061-7010	GASKET,SCREW	1	1	1
11061C	11061-7096	GASKET,INSULATOR	2	2	2
13107	13107-7018	SHAFT	1	1	1
15004	15004-0818	CARBURETOR-ASSY	1	1	1
16014	16014-7011	SCREW-PILOT AIR	1	1	1
16020	16020-7003	CHAMBER-FLOAT	1	1	1
16025	16025-7006	VALVE-THROTTLE	1	1	1
16030	16030-7003	VALVE-FLOAT	1	1	1
16031	16031-7002	FLOAT	1	1	1
16041	16041-7018	SHAFT-CARBURETOR,THROTTLE	1	1	1
16041A	16041-7049	SHAFT-CARBURETOR,CHOKE	1	1	1
16073	16073-0876	INSULATOR		1	1
16073A	16073-7007	INSULATOR	1		
16186	16186-7001	VALVE-ASSY-CHOKE	1	1	1
21188	21188-7002	SOLENOID	1	1	1
39076	39076-7001	LIMITER	1	1	1
49121	49121-7019	NOZZLE-MAIN	1	1	1
59076	59076-7020	MANIFOLD-INTAKE	1	1	1
92004	92004-2149	STUD,6X98	2	2	2
92009	92009-2083	SCREW	2	2	2
92009A	92009-2349	SCREW	1	1	1
92063	92063-7046	JET-MAIN,#100 (OPTION)	1	1	1
92063A	92063-7047	JET-MAIN,#098 (OPTION)	1	1	1
92063B	92063-7156	JET-MAIN,#102	1	1	1
92066	92066-2204	PLUG	1	1	1
92066A	92066-2244	PLUG	1	1	1
92093	92093-0593	SEAL	1	1	1
92093A	92093-0594	SEAL	1	1	1
92145	92145-0931	SPRING	1	1	1
92145A	92145-1579	SPRING	1	1	1
92145B	92145-7015	SPRING	1	1	1
92200	92200-0848	WASHER	1	1	1
92200A	92200-2061	WASHER,9.8X5.5X1.0	1	1	1
130	130AA0635	BOLT-FLANGED,6X35	4	4	4

E0190-B648B

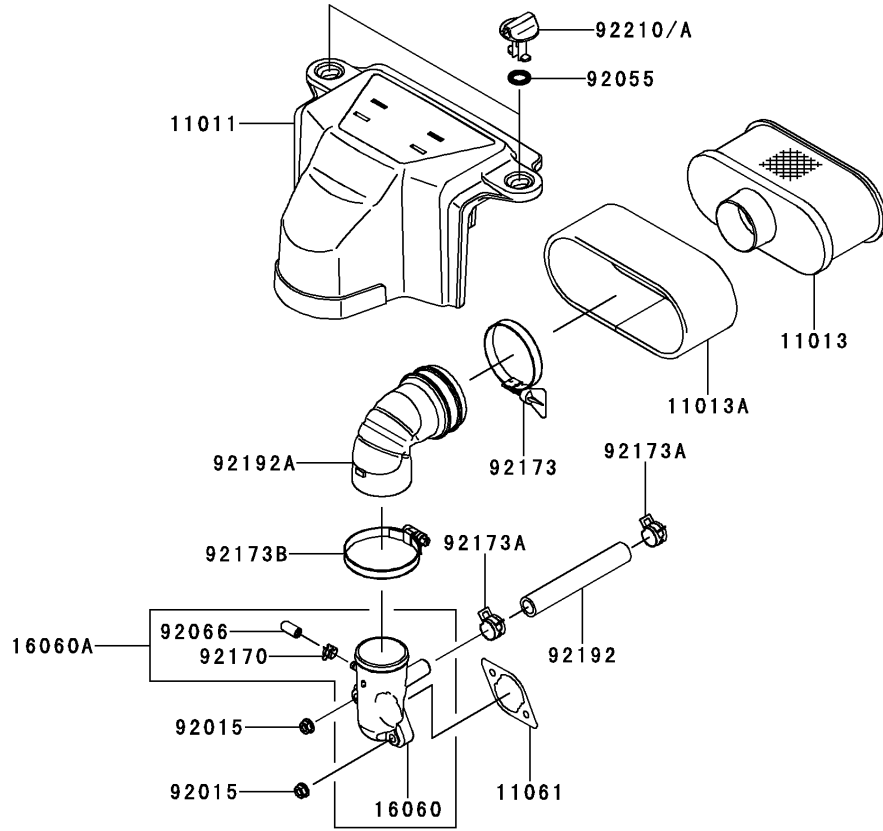

09. AIR-FILTER/MUFFLER

Ref. No.	Part No.	Description	Quantity		
			AG82	BG82	CG82
11011	11011-0787	CASE-AIR FILTER	1	1	1
11013	11013-0752	ELEMENT-AIR FILTER	1	1	1
11013A	11013-7046	ELEMENT-AIR FILTER	1	1	1
11060	11060-7016	GASKET,MUFFLER	2	2	2
11061	11061-7095	GASKET,AIR CLEANER	1	1	1
16060	16060-0740	PIPE-INTAKE	1	1	1
16060A	16060-0742	PIPE-INTAKE	1	1	1
92015	92015-1367	NUT,FLANGED,6MM	2	2	2
92055	92055-7025	RING-O	2	2	2
92066	92066-0095	PLUG	1	1	1
92170	92170-2042	CLAMP	1	1	1
92173	92173-1001	CLAMP	1	1	1
92173A	92173-7003	CLAMP	2	2	2
92173B	92173-7009	CLAMP	1	1	1
92192	92192-7146	TUBE,12.6X18.6X118	1	1	1
92192A	92192-7164	TUBE,A/C	1	1	1
92210	92210-1730	NUT	2	2	2
92210A	92210-7038	NUT	2		

PARTS SHIPPED LOOSE

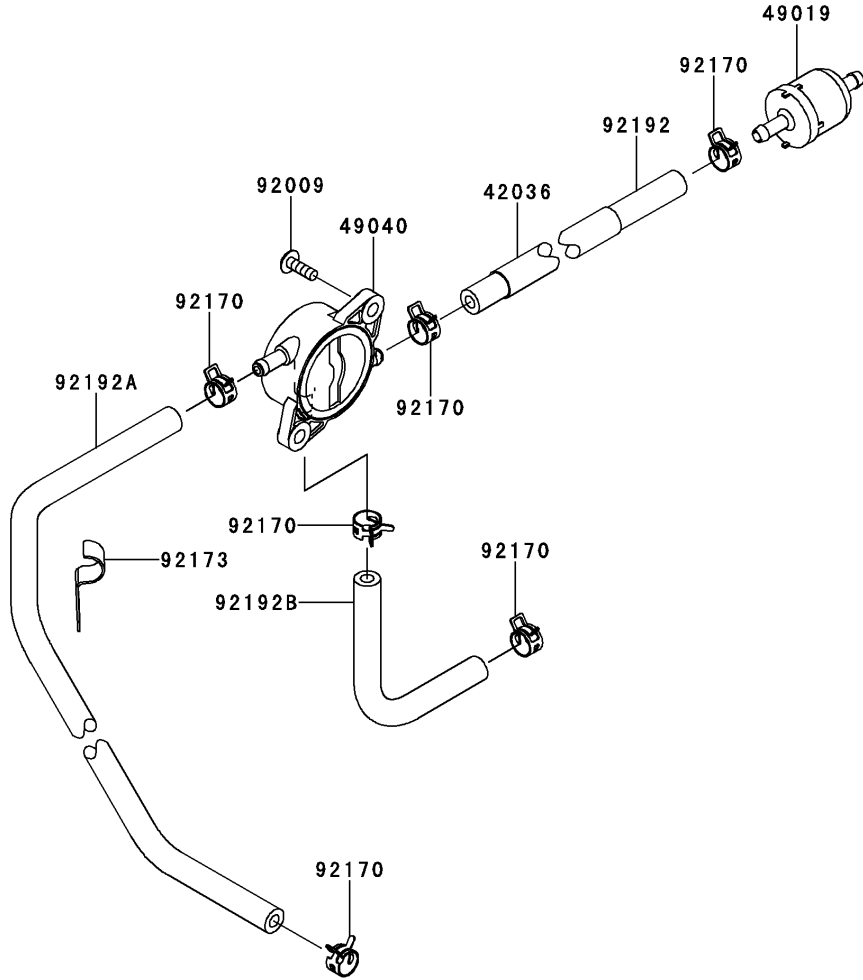

E0200-A957A



10. FUEL-TANK/FUEL-VALVE

Ref. No.	Part No.	Description	Quantity		
			AG82	BG82	CG82
42036	42036-7015	SLEEVE	1	1	1
49019	49019-0027	FILTER-FUEL	1	1	1
49040	49040-0770	PUMP-FUEL	1	1	1
92009	92009-2303	SCREW	2	2	2
92170	92170-2009	CLAMP	6	6	6
92173	92173-1000	CLAMP	1	1	1
92192	92192-1551	TUBE,6.35X12.7X185	1	1	1
92192A	92192-1560	TUBE,6.35X12.7X375	1	1	1
92192B	92192-7148	TUBE,6.4X12.7X150	1	1	1

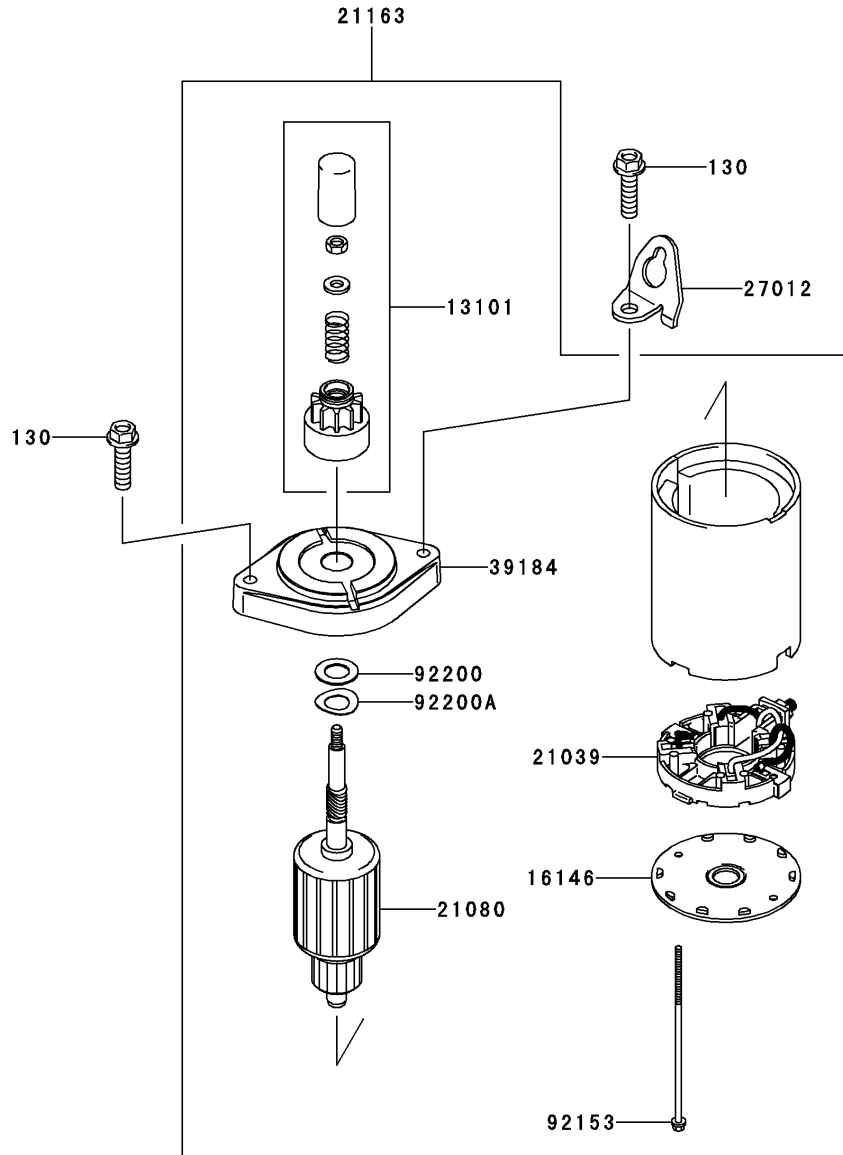
E0210-A725A



11. STARTER

Ref. No.	Part No.	Description	Quantity		
			AG82	BG82	CG82
13101	13101-0650	GEAR-ASSY	1	1	1
16146	16146-7013	COVER-ASSY	1	1	1
21039	21039-7002	BRUSH	1	1	1
21080	21080-0009	ARMATURE	1	1	1
21163	21163-0749	STARTER-ELECTRIC	1	1	1
27012	27012-7008	HOOK	1	1	1
39184	39184-0019	BRACKET-ASSY	1	1	1
92153	92153-7034	BOLT	2	2	2
92200	92200-7023	WASHER	1	1	1
92200A	92200-7024	WASHER	1	1	1
130	130BA0830	BOLT-FLANGED,8X30	2	2	2

F0290-B823A

12. LABEL

Ref. No.	Part No.	Description	Quantity		
			AG82	BG82	CG82
56071	56071-0366	LABEL-WARNING	1	1	1
56080	56080-0752	LABEL-BRAND	1	1	1

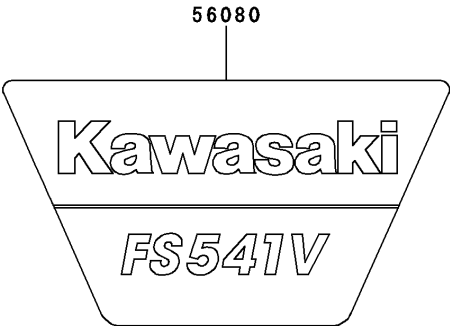
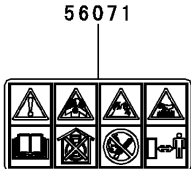

F0300-A001A

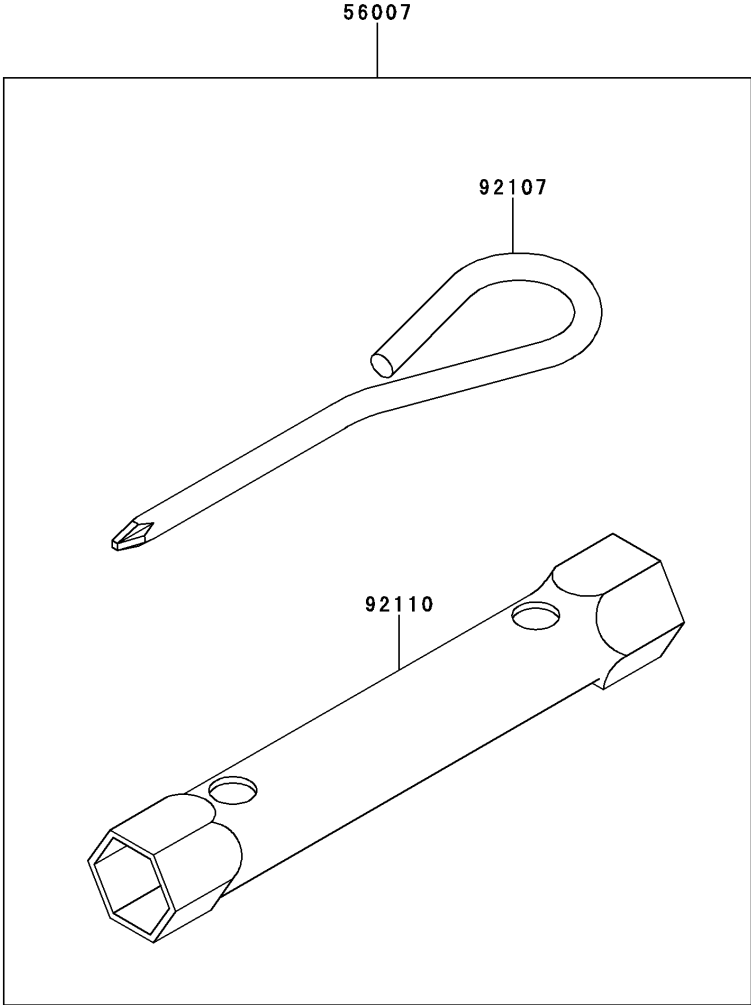

13. TOOL

Ref. No.	Part No.	Description	Quantity		
			AG82	BG82	CG82
56007	56007-2051	TOOLKIT	1	1	1
92107	92107-2057	TOOL-DRIVER	1	1	1
92110	92110-2051	TOOL-WRENCH,19X21	1	1	1

FS541V- AG82/BG82/CG82

NUMERICAL PARTS INDEX

Part No.	Fig No.	Part No.	Fig No.	Part No.	Fig No.	Part No.	Fig No.	Part No.	Fig No.	Part No.	Fig No.
11004-7027	01	14075-0037	04	49065-7006	04	92066-0880	01	92192-1551	10		
11008-7050	01	14075-0707	04	49065-7007	04	92066-0881	01	92192-1560	10		
11008-7051	01	14091-7064	01	49078-7002	03	92066-0881	06	92192-7146	09		
11011-0787	09	15004-0818	08	49089-0987	05	92066-2204	08	92192-7148	10		
11013-0752	09	16014-7011	08	49089-0988	05	92066-2223	01	92192-7164	09		
11013-7046	09	16020-7003	08	49103-7017	07	92066-2244	08	92200-0848	08		
11022-0046	01	16025-7006	08	49113-0047	07	92070-7004	06	92200-0945	03		
11022-0047	01	16030-7003	08	49118-0809	03	92072-7003	06	92200-2061	08		
11055-7009	03	16031-7002	08	49120-0883	01	92093-0593	08	92200-2151	03		
11060-7016	09	16041-7018	08	49121-7019	08	92093-0594	08	92200-7002	06		
11061-0877	08	16041-7049	08	510A5100	06	92104-0007	01	92200-7023	11		
11061-1285	01	16060-0740	09	55020-0900	05	92107-2057	13	92200-7024	11		
11061-7009	08	16060-0742	09	555A0420	04	92110-2051	13	92200-7048	03		
11061-7010	08	16073-0876	08	56007-2051	13	92140-7003	04	92210-1730	09		
11061-7083	01	16073-7007	08	56071-0366	12	92140-7005	03	92210-7038	09		
11061-7094	01	16126-7020	01	56080-0752	12	92145-0931	08				
11061-7095	09	16146-7013	11	59031-7017	06	92145-1579	08				
11061-7096	08	16154-7010	04	59041-0008	05	92145-1653	03				
12004-0740	03	16154-7011	04	59041-0024	05	92145-1809	04				
12005-0760	03	16171-0035	07	59066-0044	05	92145-1811	07				
12005-0793	03	16186-7001	08	59071-0743	01	92145-7004	07				
12009-7001	03	172BA0822	01	59076-7020	08	92145-7015	08				
12011-2056	03	21039-7002	11	59231-0712	04	92150-2182	07				
12016-0040	03	21066-7017	06	59231-0746	04	92151-7017	02				
12032-7001	03	21080-0009	11	670B2011	01	92152-1689	03				
13001-7031	02	21163-0749	11	670D2016	04	92153-7007	05				
13002-7001	02	21171-0738	06	92004-2149	08	92153-7008	04				
13008-7006	02	21171-0740	06	92009-2083	08	92153-7034	11				
13025-7010	02	21188-7002	08	92009-2303	06	92153-7054	01				
13029-7011	02	21193-0035	06	92009-2303	10	92153-7100	03				
13031-0814	02	23062-7022	05	92009-2349	08	92154-1267	03				
13070-7017	03	26011-2234	06	92015-1367	09	92154-2687	05				
130AA0635	08	26011-7025	06	92026-7007	05	92154-2697	07				
130BA0612	04	26031-7040	06	92033-0778	03	92154-2842	02				
130BA0620	06	26031-7047	06	92033-0780	02	92154-2938	01				
130BA0625	01	27012-0721	01	92038-2101	02	92154-2938	04				
130BA0830	11	27012-7008	11	92039-0751	05	92154-2938	05				
130CA0870	01	311BA0600	07	92043-0858	01	92154-2938	07				
13101-0650	11	312AA0500	07	92043-1263	01	92154-7003	06				
13107-7018	08	312AA0600	03	92049-7001	01	92170-2009	10				
13107-7049	07	32155-2214	01	92049-7010	01	92170-2042	09				
13116-7008	03	39076-7001	08	92049-7019	01	92170-7001	07				
13251-0718	02	39129-0725	07	92049-7028	01	92172-0792	07				
13271-7007	03	39184-0019	11	92055-0892	04	92172-0870	01				
13271-7021	03	411AA0600	07	92055-7025	09	92172-0870	07				
13271-7038	07	42036-7015	10	92063-7046	08	92172-7018	06				
13272-1374	01	42036-7021	03	92063-7047	08	92173-1000	10				
13272-1487	05	49015-0019	01	92063-7156	08	92173-1001	09				
13272-7011	04	49019-0027	10	92066-0095	09	92173-7003	09				
14037-7008-9H	05	49040-0770	10	92066-0774	04	92173-7009	09				

Kawasaki Heavy Industries, Ltd.

Motorcycle & Engine Company

Part No. 99908-6185-01